

## DEHUMIDIFYING DRYER DES111-112-113

### DESCRIZIONE / DESCRIPTION:

Soffiante ad alta prevalenza / *High performance blower.*

Impostazione programmi differenti / *difference programs setting.*

N°1 Torre setacci molecolari / *No.1 Molecular sieves dessicant tower.*

Dew Point -40°C / *Dew Point -40°C.*

Funzionamento senza acqua / *No water.*

Manutenzioni programmate / *Programmable maintenances.*

Ciclo di trattamento continuo / *Treatment cycle in continuous.*



MODELLO MODEL	Portata d'aria Air Flow	Temperatura massima Max Temperature	Soffiante Blower	Potenza totale Total Power	Consumo Consumption
DES111	50 m <sup>3</sup> /h	140 °C	0,2 kW	4,5 (5,7*) kW	a/at 80°C 1,5 kW
DES112	80 m <sup>3</sup> /h	140 °C	0,4 kW	6,6 (7,4*) kW	a/at 80°C 2 kW
DES113	100 m <sup>3</sup> /h	140 °C	0,75 Kw	6,9 (7,7*) kW	a/at 80°C 2,5 kW

### ESEMPI DI APPLICAZIONE / EXAMPLE OF APPLICATION:

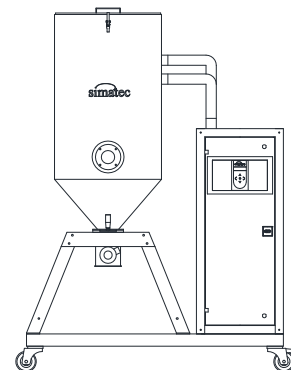
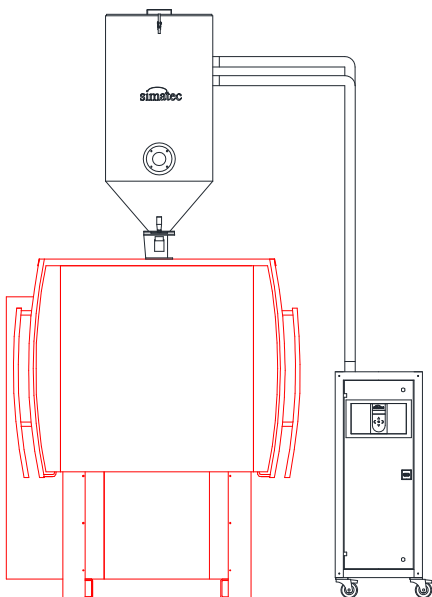

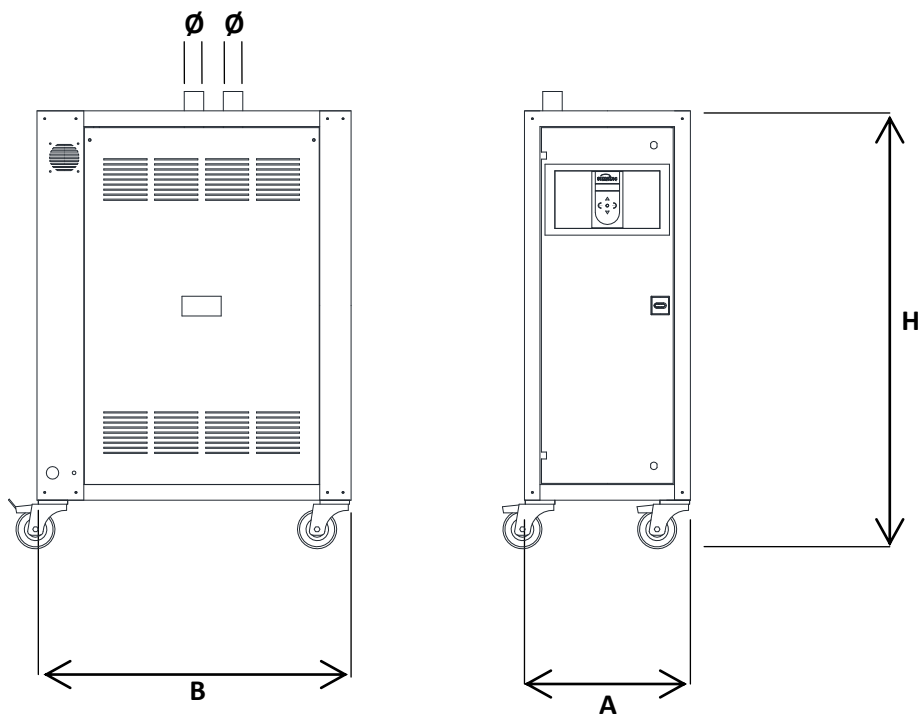

DIMENSIONI / DIMENSIONS				
MODELLO MODEL	A (mm)	B (mm)	H (mm)	Ø (mm)
DES111	424	800	1125	50
DES112				
DES113				

